



Coupled Inductors and the Linear Transformer Model

By: Larry Schooley

University of Arizona

Department of Electrical and Computer Engineering

Tucson, AZ

Abstract:

In this lab you will investigate the use of the linear transformer model to describe the behavior of coupled inductors. The first portion of the lab will involve determination of the parameters used in the linear transformer model. These parameters will then be verified by using them to predict the behavior of a circuit which includes coupled inductors.

Equipment:

- Agilent 54600B Oscilloscope
- Agilent 33120A Function/Arb Generator

- 1) For this lab the internal resistance of the function generator, R_s , must be determined exactly. Inductances are difficult to measure correctly (even with specialized equipment), so accuracy will become especially important in your calculations of component values. A simple model of the function generator is an independent voltage source with a series resistor (see the left side of figure 2). However, R_s is effectively inside the function generator box, so you cannot directly measure it with an ohmmeter. Keeping this in mind, develop an experimental method to determine the value of R_s . (Hint: Think about how a voltage divider works.)
- 2) Consider the linear transformer model shown in figure 1. Develop an experimental procedure for determining the magnitude of the self-inductance of the coils. (Note: this procedure cannot include the use of a L-C meter.)

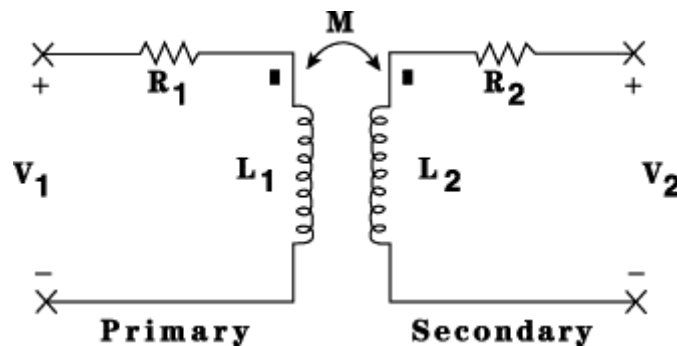

Figure 1: The Linear Transformer Model



- 3) From the linear transformer model in figure 1, it is possible to determine the mutual inductance, M , in two steps:
 - a. The first step is to determine I_1 , the current in the primary. Explain how this can be done in the lab.
 - b. The second step involves using I_1 to find M . Develop an equation that can be used in the lab directly to determine M .

- 4) Consider the linear transformer given in figure 2 below. Given that the frequency of the input is $f = 500$ kHz, $R_s = 50 \text{ } \Omega$, and the voltage at $V_s = 1$ Vp find:
 - a. the reflected impedance seen at the primary.
 - b. the reflected impedance seen at the secondary. (Leave the load in place and assume that $V_s = 0$ volts.)
 - c. the current through the 10 ohm load element.
 - d. the current in the primary coil.

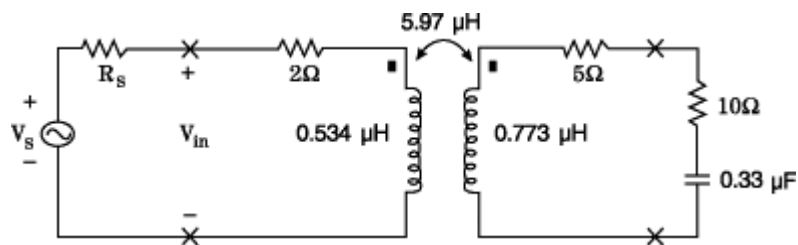

Figure 2: Loaded Linear Transformer

Experiment:

- 1). First, you will determine the linear transformer parameters. Due to the low inductance values in your transformer, a high input frequency is needed-use a frequency of 500 kHz for all sources.
 - a. Determine the internal resistance of the function generator (R_s) using the method from the Prelab.
 - b. Measure the series resistance in the primary (R_1) and then the secondary resistance (R_2).
 - c. Using the method you found in part I of the Prelab determine the self-inductance of the primary winding (L_1).
 - d. Repeat with the secondary winding (L_2).
 - e. Using the method you found in part II of the Prelab determine the mutual inductance (M).
 - f. The final thing you need to determine is the dot markings for the transformer. Assuming the dot on the primary is on the "plus" terminal, determine if the dot on the secondary should go on the "+" or "-" terminal.



Question 1:

Draw a schematic of your complete linear transformer model, labeling all of the components with their experimental values.

- 2) Load the secondary side of the transformer with a 10 ohm resistor in series with a 0.33 micro-farad capacitor. Drive the primary side of the transformer with a 1 Vp sine wave at 500 kHz. Note: you will need to set the function generator output to 1 Vp before attaching it to the circuit, otherwise you will be compensating for the loading effects of the circuit.
 - a. Measure the voltage across R1 and L1.
 - b. Determine the current in the primary.

Question 2:

Using the results of 2(a) and 2(b) above, determine the impedance seen at the terminals of the primary. Using the data from Part I you can also calculate a predicted value for this impedance. Do this and compare the results.

- c. Measure the voltage across the load.
- d. Measure the current in the secondary.

Question 3:

Compare the measured secondary current and voltage to the predicted values you find from the linear transformer model. Note: Since your values for R1, R2, L1, L2 and M will be different from those used in the prelab, you will need to put your experimental values into the model and recalculate the secondary voltage, current, and impedance.

Discussion:

Considering the basic physical construction of the transformer-two wires wound on top of each other-explain the origin of each component in the circuit model.